

HUDSON ROUND TABLE ASSEMBLY INSTRUCTIONS



PARTS AND FITTINGS PACKING DETAIL

BOX



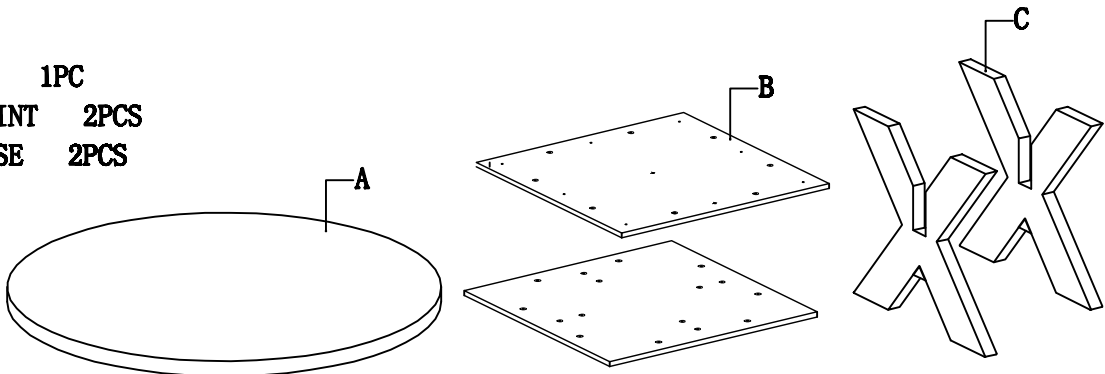

- A. TABLE TOP 1PC
- B. TABLE SPLINT 2PCS
- B. TABLE HORSE 2PCS

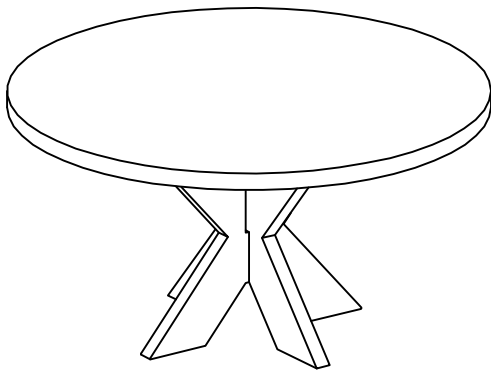

HUDSON COUNTER TOP TABLE ASSEMBLY

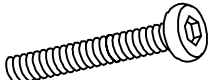

HARDWARE PACKED IN BOX

1	BOLT ø5/16" * 1-1/4"	16 PCS	2	SPRING WASHER ø8*13	16 PCS
					
3	FLAT WASHER ø8*21	16 PCS	4	Allen key 5MM	1 PCS
					

STEP1:

PLACE THE CHEST (C) UPSIDE
DOWN ON A SOFT SURFACE.

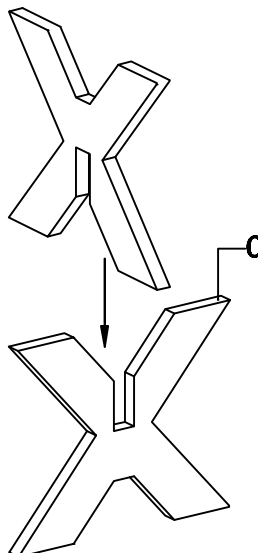

Step2:

Attach the square top (B) panel to (C) base as shown in diagram. then tighten all bolts.

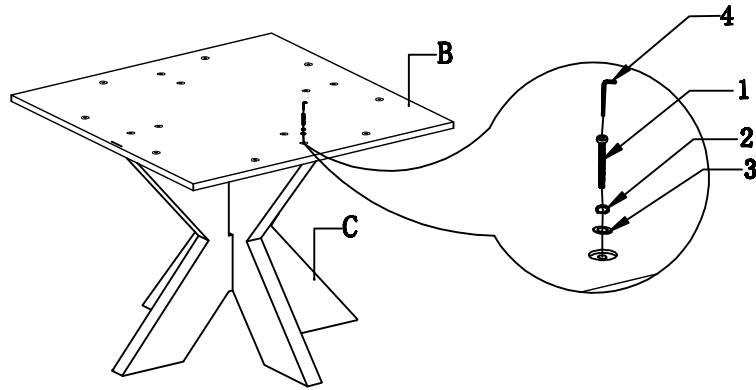

Step3:

Attach the base from above step to round top panel as shown in diagram. then tighten all bolts.

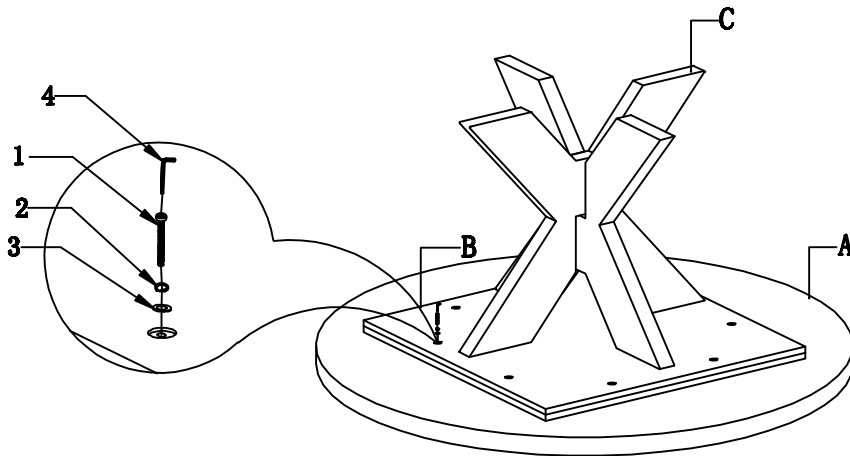

Step4:

Turn the table to upright position.

