

CONTOUR BED STORAGE 2 DRAWER

FULL/QUEEN/E-KING SIZE
ASSEMBLY INSTRUCTIONS



PARTS AND FITTING PACKAGING DETAIL

BOX #1

- A. HEADBOARD PANEL 1 PC
- B. HEADBOARD LEG 1 PC
- C. FOOTBOARD 1 PC

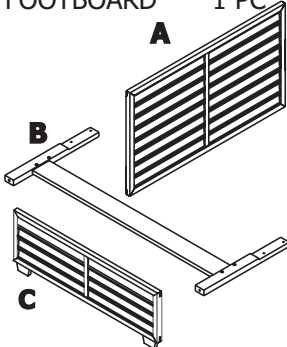

BOX #2

- D. SIDERAIL 1 PC

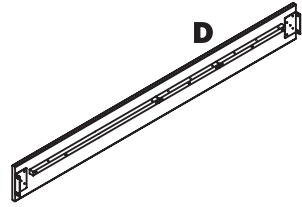

HARDWARE* PACKED IN BOX #2

A	PHILLIPS HEAD BOLTS 20MM	4 PCS	B	WASHERS 8MM	4 PCS

BOX #3

- E. CENTER SLAT 1 PC
- F. LEG SUPPORT 4 PCS
- G. SIDERAIL STORAGE 1 PC
- H. STORAGE FEET 6 PCS

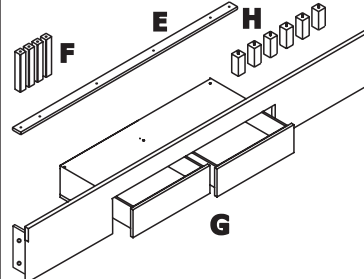

BOX #4

- I. ROLL SLAT 12 PCS

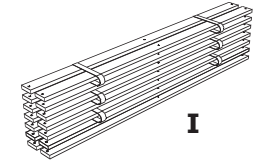

TOOL REQUIRED :
PHILLIPS HEAD SCREW DRIVER (NOT PROVIDED)

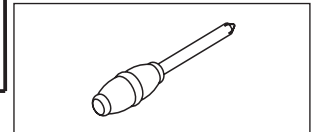

CONTOUR BED STORAGE 2 DRAWER ASSEMBLED

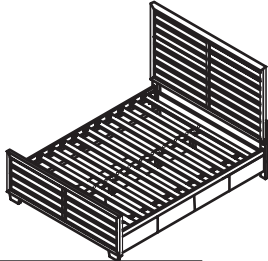

HARDWARE* PACKED IN BOX #1

1	ALLEN BOLTS 6 X 50 HITAM	4 PCS	2	ALLEN KEY	1 PC

HARDWARE* PACKED IN BOX #3

1	PHILLIPS HEAD BOLTS 20MM	4 PCS	2	WOOD SCREW Ø8X30MM	8 PCS	3	ALLEN KEY	1 PC
4	ALLEN BOLT 40MM	10 PCS	5	WASHER 8MM	4 PCS	YOUR BOX MAY CONTAIN EXTRA HARDWARE		

STEP 1 :

FOLLOW THE ILLUSTRATION, PUT THE ALLEN BOLT IN THE PREDILLED HOLE ARE TURNING TO UNIFY THE HEADBOARD LEG (B) TO THE HEADBOARD PANEL (A)

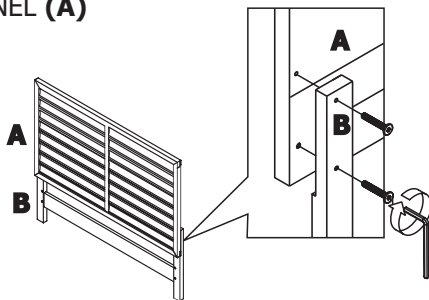

STEP 2 :

FIX SIDERAIL (D) TO THE HEADBOARD (A/B) USING PHILLIPS HEAD BOLTS (1) AND WASHERS (5).

DO NOT TIGHTEN BOLTS COMPLETELY UNTIL ASSEMBLY IS COMPLETED

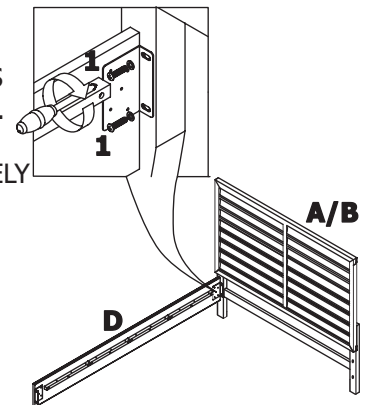

STEP 3 :

FIX THE OTHER END OF SIDERAIL (D) TO THE FOOTBOARD (C).

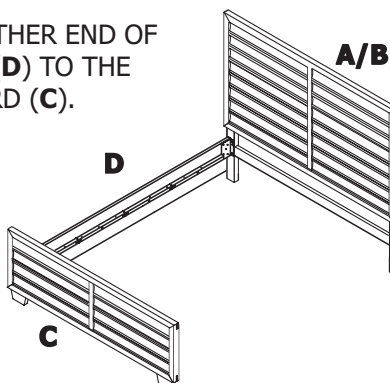

STEP 4 :

REMOVE PLASTIC COVER FROM STORAGE FEET (H) BOLTS. FOLLOW THE ILLUSTRATION TO FIX STORAGE FEET (H) TO UNDERNEATH OF STORAGE DRAWER (G).

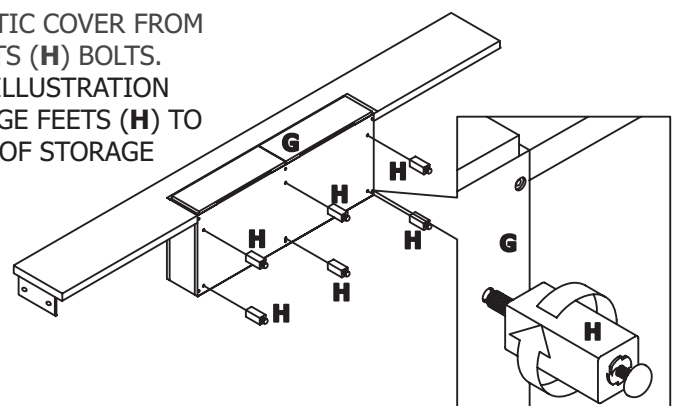

STEP 5 :

FOLLOW THE ILLUSTRATION TO FIX SIDERAIL STORAGE (G) TO HEADBOARD ASSY (A/B) & FOOTBOARD (C) USING PHILLIPS BOLTS (4) AND WASHER (5).

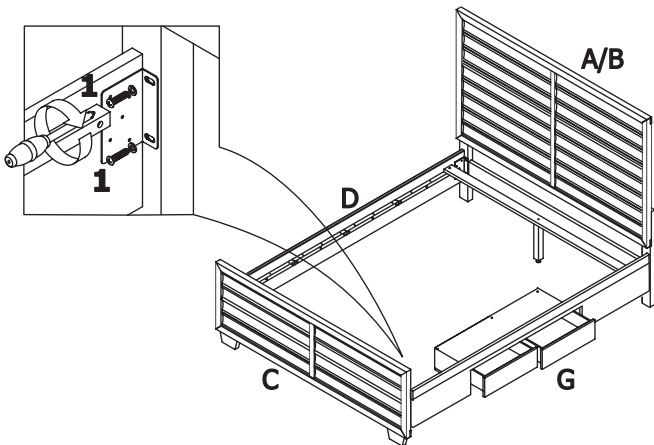
**STEP 6 :**

TURN LEVELER UNDERNEATH STORAGE FEET (H) TO ADJUST THE SIDERAIL STORAGE (G) LEVEL AS SHOWN ON ILLUSTRATION.

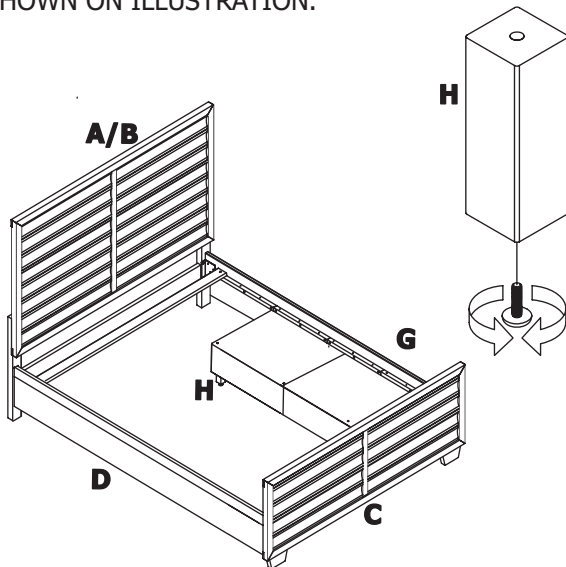
**STEP 7 :**

FIX LEG SUPPORTS (F) TO CENTER SLAT (E) USING ALLEN BOLTS (4). SLIDE ALLEN BOLTS (4) INTO PREDRILLED HOLES THAT DON'T HAVE A T-NUT IN IT ON THE CENTER SLAT (E). MAKE SURE THE T-NUT IS FACING THE FLOOR.

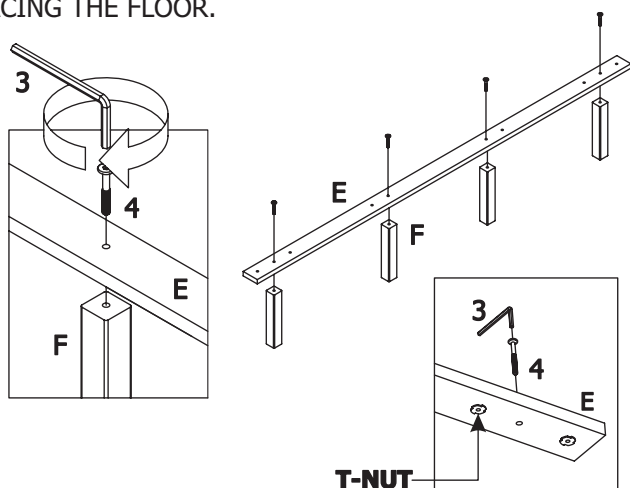
**STEP 8 :**

FOLLOW THE ILLUSTRATION TO SPREAD OUT ALL THE ROLL SLATS (I). FIX THE CENTER SLAT (E) TO THE ROLL SLATS (J) BY SLIDING IN THE ALLEN BOLTS (4) THROUGH THE HOLES FROM THE TOP OF ROLL SLATS (I) TO THE CENTER SLAT (E). USE THE 1ST, 2ND, 5TH, 8TH, 11TH AND 12TH PRE-DRILLED HOLES ON ROLL SLATS (I).

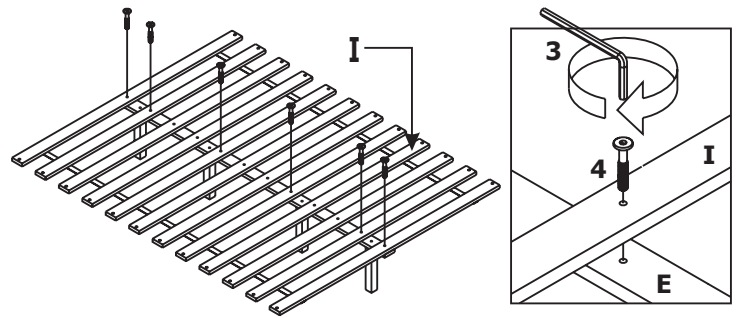
**STEP 9 :**

FOLLOW THE ILLUSTRATION TO PLACE THE ROLL SLATS (I) ON THE BED FRAME. SPREAD ROLL SLATS (I) ON BED FRAME. FIX 1ST, 6TH, 7TH, AND 12TH ROLL SLATS TO BED FRAME USING WOOD SCREWS (2). USE THE PILOT HOLES ON SIDERAIL (D) & SIDERAIL STORAGE (G) AS YOUR REFERENCE, FOR EASY ASSEMBLY. YOU MAY NEED TO ADJUST SIDERAIL (D) & SIDERAIL STORAGE (G) POSITION TO LINE UP THE HOLES. MAKE SURE ALL BOLTS AND SCREWS ARE TIGHTENED BEFORE USING.

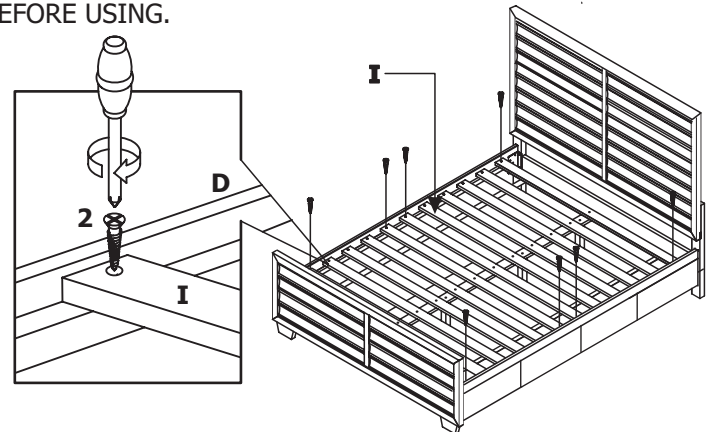
**INSTRUCTIONS FOR ADJUSTING LEVELERS:**

THE LEVELERS ARE LOCATED ON THE UNDERSIDE OF EACH OF THE LEG SUPPORTS. PLEASE ADJUST THE LEVELERS BY FOLLOWING THESE INSTRUCTIONS.

- 1** MAKE SURE THE LEVELERS ARE FLUSH WITH THE BOTTOM EDGE OF THE POSTS
- 2** ADJUST THE LEVELERS BY TURNING UNTIL THE LEG SUPPORTS MATCH EACH OTHER IN HEIGHT

