

PIAZZA PLATFORM

C-KING SIZE

ASSEMBLY INSTRUCTIONS



PARTS AND FITTING PACKAGING DETAIL

BOX #1

A. HEADBOARD 1 PC

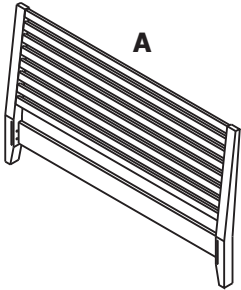

BOX #2

B. FOOTBOARD 1 PC

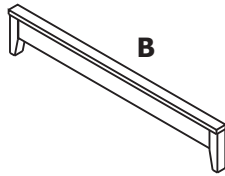

BOX #3

C. SIDERAILS 2 PCS
 D. CENTER SLAT 1 PC
 E. CENTER LEG 4 PCS
 HARDWARE BOX

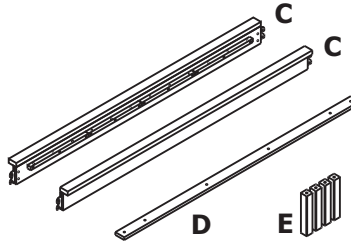

BOX #4

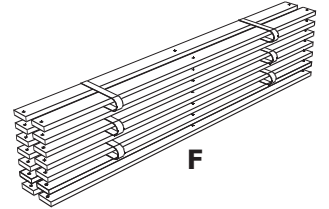

F. BED SLATS 14 PCS

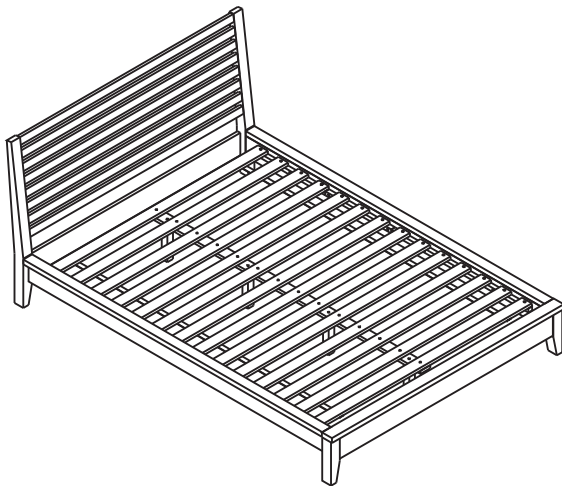

PIAZZA PLATFORM ASSEMBLED

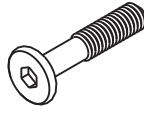

HARDWARE PACKED IN BOX #3

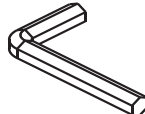
1	ALLEN BOLT 40MM	10 PCS	2	WOOD SCREW Ø8X30MM	12 PCS
					
3	ALLEN KEY	1 PC			
					

TOOL REQUIRED :

PHILLIPS HEAD SCREW
DRIVER (NOT PROVIDED)

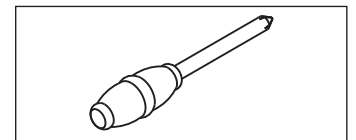

STEP 1 :

FIX ONE OF THE SIDERAILS (C) TO THE HEADBOARD (A) BY SLIDING IN THE HOOK INSTALLED AT THE END OF THE SIDERAIL (C) TO THE HEADBOARD (A), AND PUSH THE SIDERAIL (C) DOWN TO SECURE THE CONNECTION.

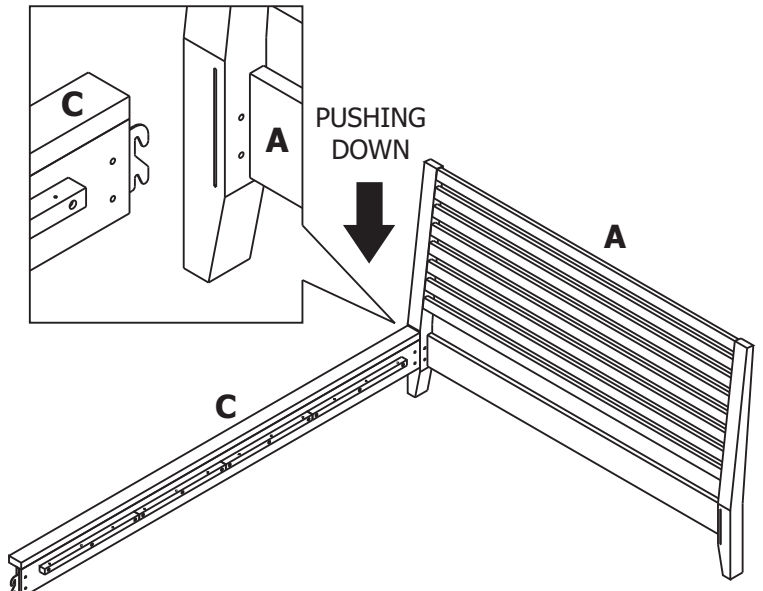

STEP 2 :

FIX THE OTHER END OF THE SIDERAIL (C) TO THE FOOTBOARD (B).

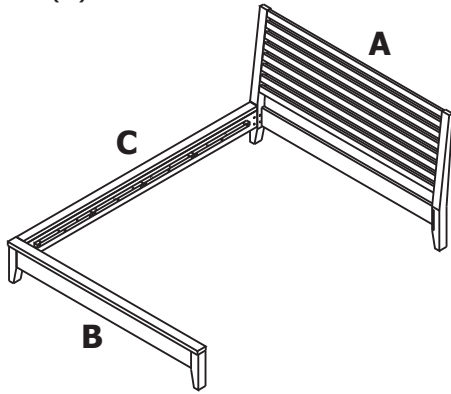
**STEP 3 :**

FIX THE OTHER SIDERAIL (C) TO THE HEADBOARD (A) AND FOOTBOARD (B).

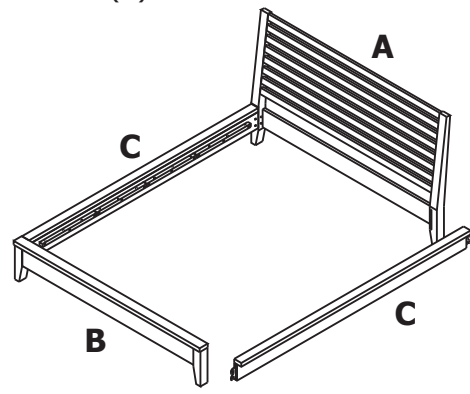
**STEP 4 :**

FIX CENTER LEGS (E) TO CENTER SLAT (D) USING ALLEN BOLTS (1). SLIDE ALLEN BOLTS (1) INTO PREDRILLED HOLES THAT DON'T HAVE A T-NUT IN IT ON THE CENTER SLAT (D). MAKE SURE THE T-NUT IS FACING THE FLOOR.

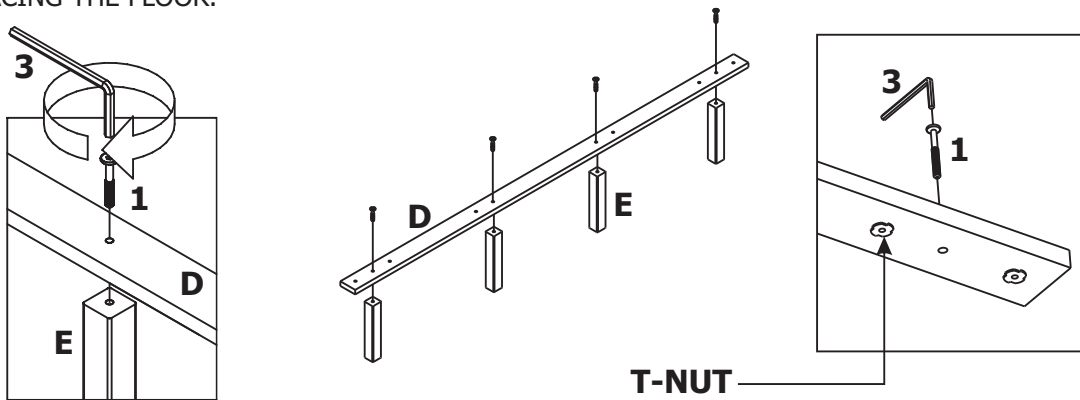
**STEP 5 :**

FOLLOW THE ILLUSTRATION TO SPREAD OUT ALL THE BED SLATS (F) ON THE BED FRAME, AND FIX THE BED SLATS (F) USING WOOD SCREWS (2). USE THE PILOT HOLES ON THE SIDERAILS (C) AS YOUR REFERENCE, FOR EASY ASSEMBLY. YOU MAY NEED TO ADJUST THE SIDERAILS (C) POSITION TO LINE UP THE HOLES.

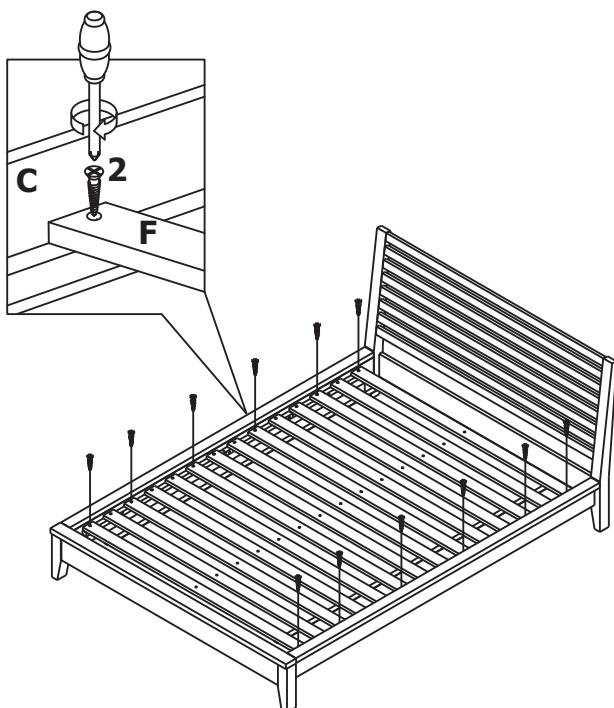
**STEP 6 :**

SLIDE IN THE CENTER SLAT (D) UNDER THE BED SLATS (F). USE THE 1ST, 2ND, 5TH, 10TH, 13TH AND 14TH PRE-DRILLED HOLES ON BED SLATS (F) FROM HEADBOARD(A) / FOOTBOARD (B) SIDE. FIX THE CENTER SLAT (D) TO THE BED SLATS (F) BY SLIDING IN THE ALLEN BOLTS (1) THROUGH THE HOLES FROM THE TOP OF BED SLATS (F) TO THE CENTER SLAT (D).

TIGHTEN ALL BOLTS AND SCREWS BEFORE USAGE.

