

ASSEMBLY INSTRUCTION

***DO NOT TIGHTEN SCREWS UNTIL COMPLETELY ASSEMBLED**

ATTENTION : BEFORE ASSEMBLING THE CHAIR, PULL THE FABRIC OUT FROM THE BOTTOM OF SEAT FRAME FIRSTLY . (PLEASE NOT PULL FORCIBLY IN CASE OF THE FABRIC BEING TORN)

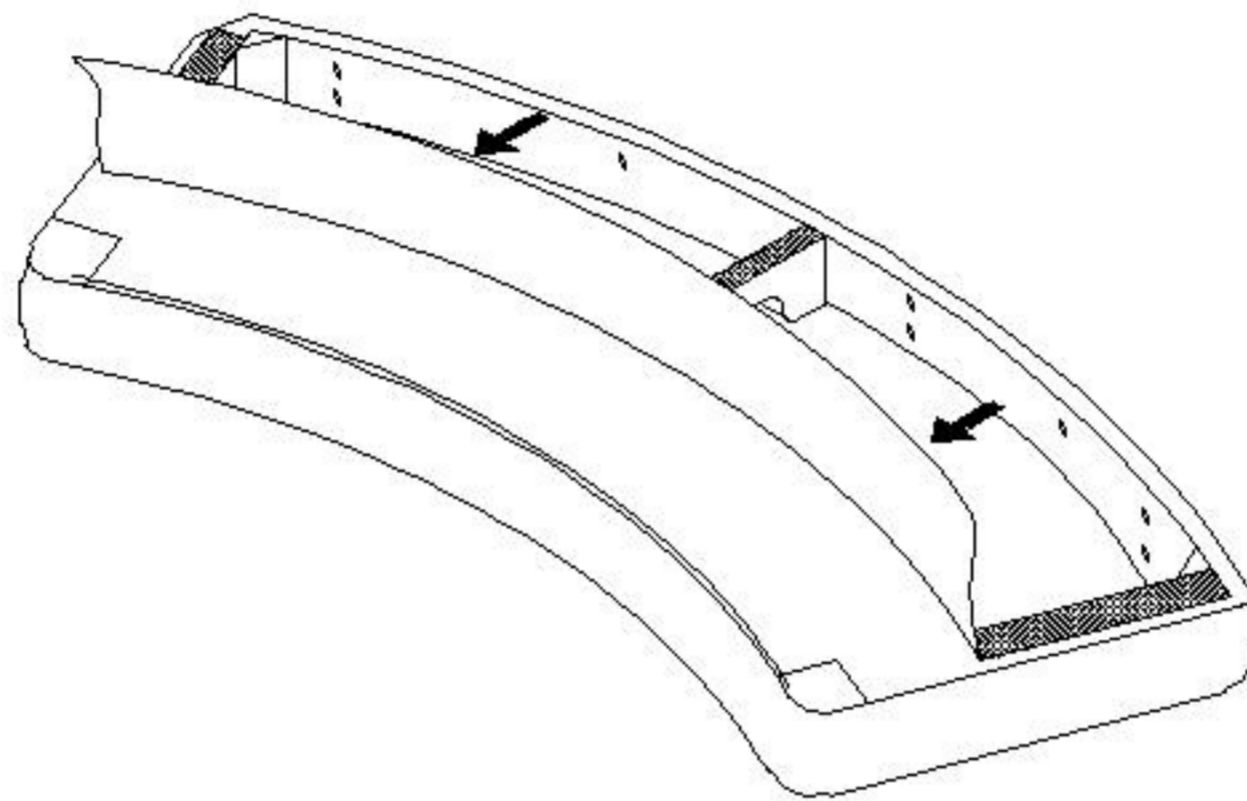

AFTER ASSEMBLING CHAIR, LINE UP THE FABRIC ON THE BOTTOM OF SEAT FRAME , AND STICK IT ON .

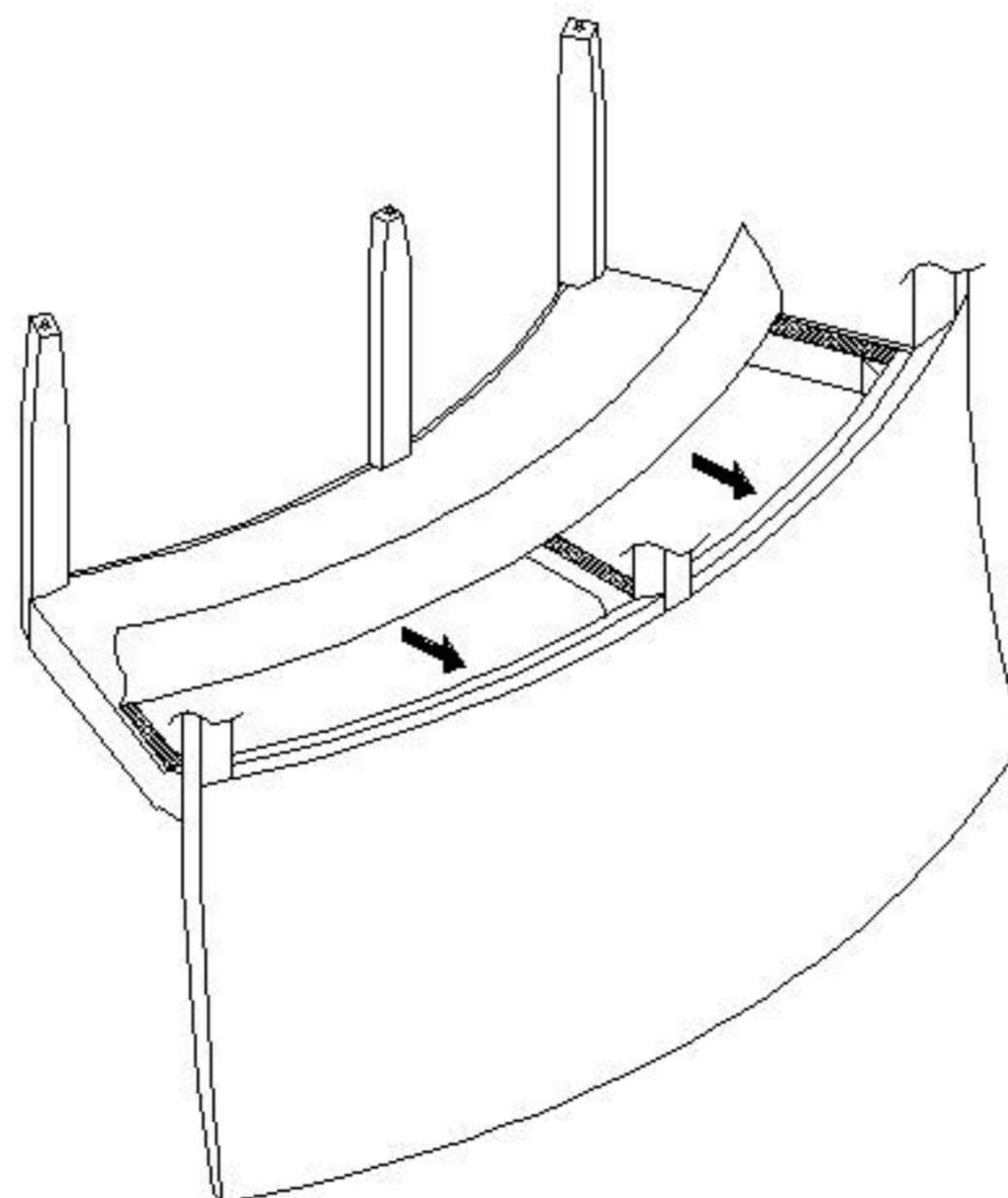

ASSEMBLY INSTRUCTION

***DO NOT TIGHTEN SCREWS UNTIL COMPLETELY ASSEMBLED**

STEP1: AS PICTURE, INSERT THE WOOD DOWEL (B) INSIDE CHAIR BACK (J).

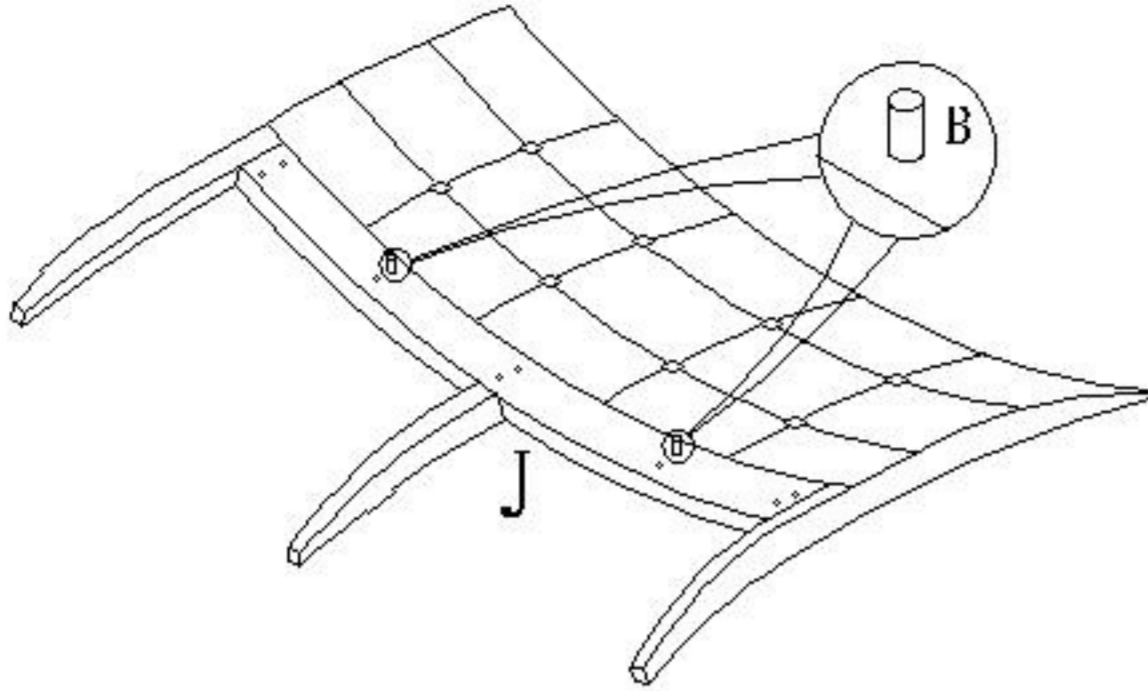

STEP 2: PUT THE SEAT FRAME (I) TO THE CHAIR BACK (J) WITH HOLES TO HOLES, THEN SCREW THE BOLTS (F) INSIDE THE HOLES BY (A/C/D/F).

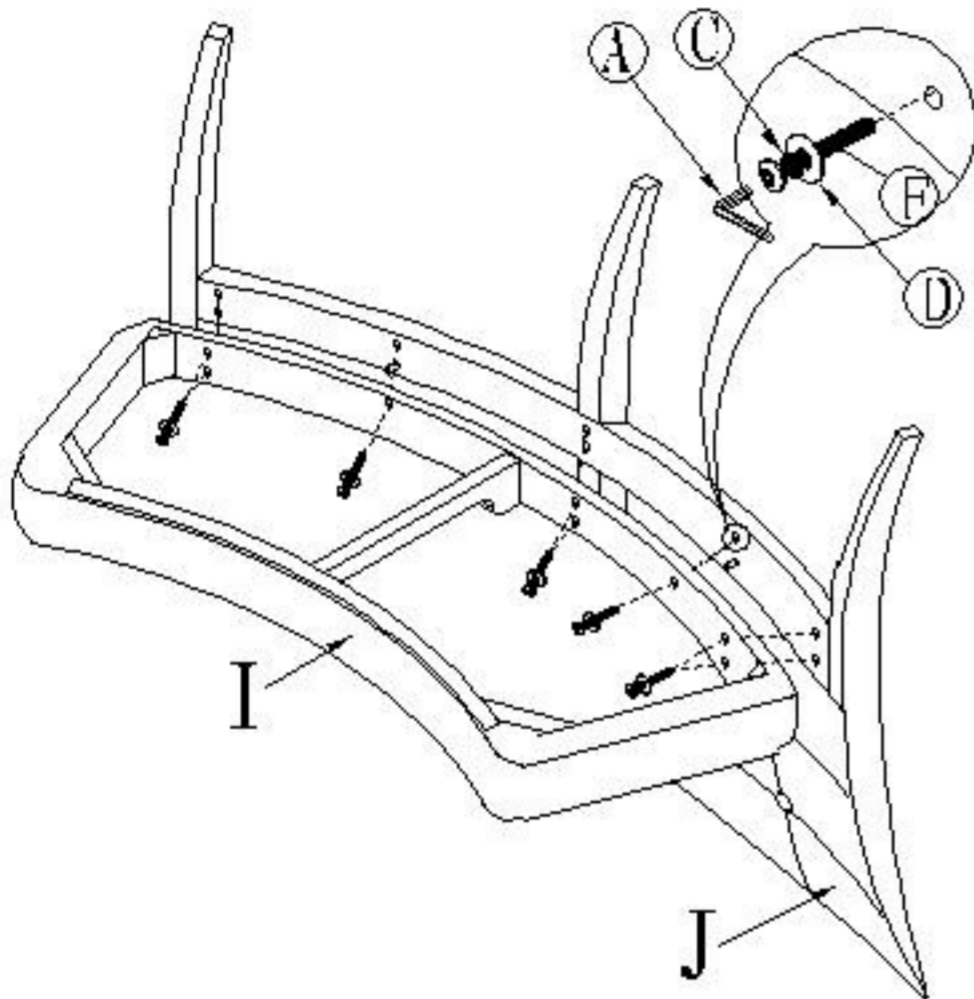



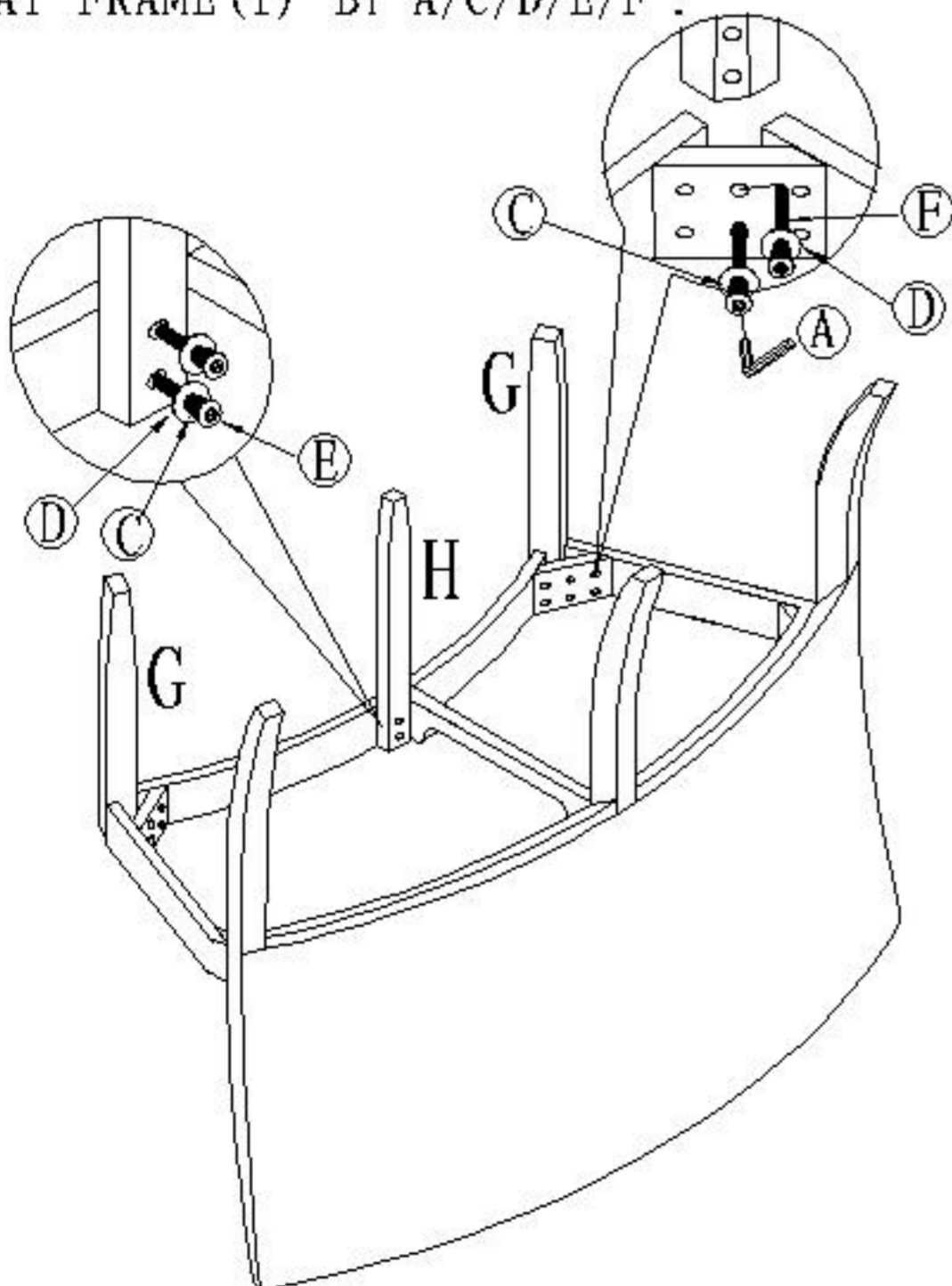

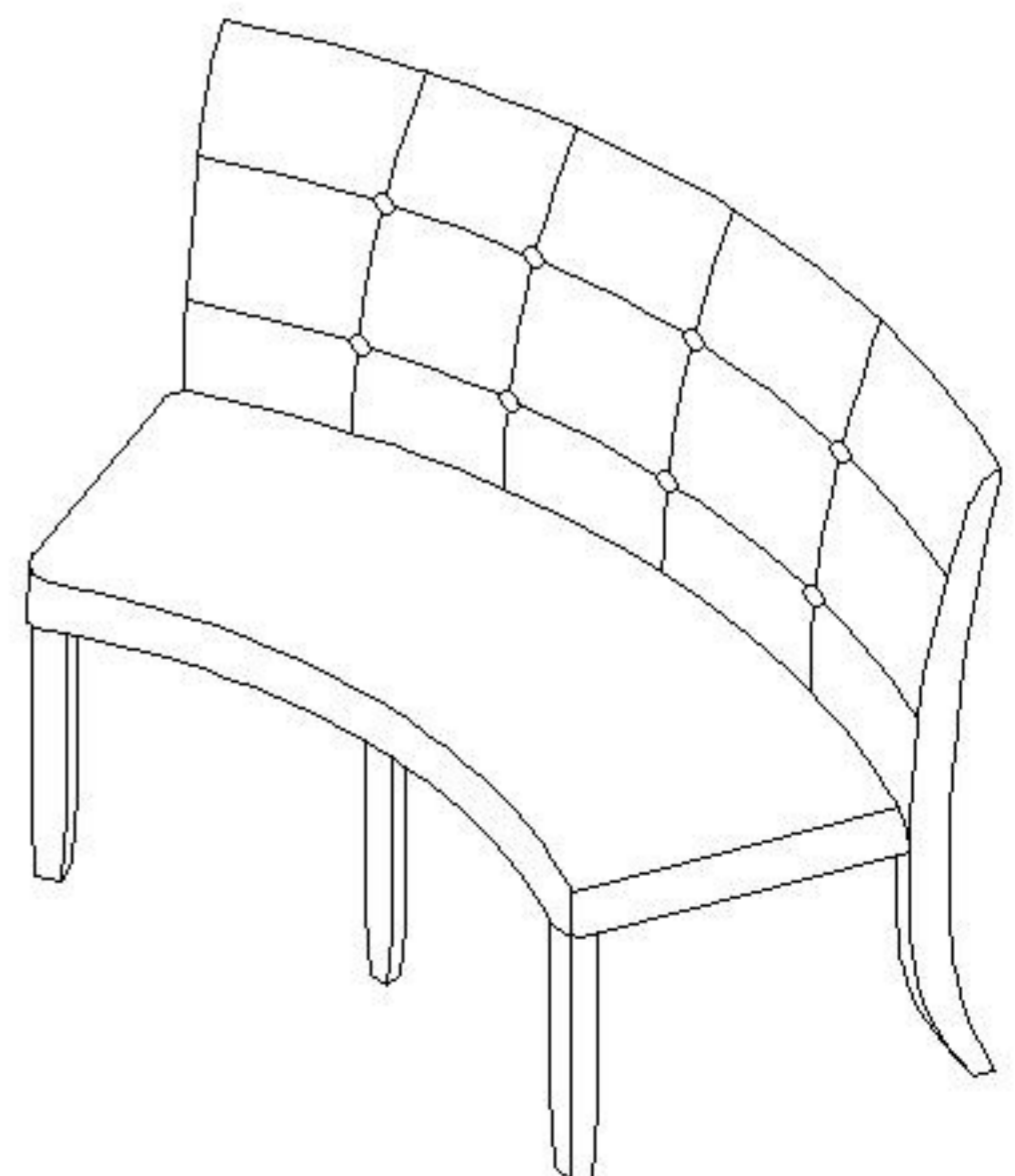

STEP3: SCREW THGHTLY THREE OF FRONT LEGS (H/G) INSIDE SEAT FRAME (I) BY A/C/D/E/F .



STEP4: PUT THE CHAIR UP.

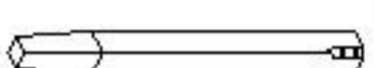
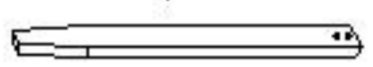
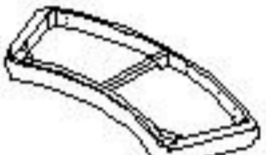

NO	DESCRIPTION	QTY
A	ALLEN WRENCH $\varnothing \frac{3}{16}$ " 	1PC
B	WOOD DOWEL $\varnothing 10 * 10 \text{mm}$ 	2PCS
C	LOCK WASHER $\varnothing \frac{5}{16}$ " 	14PCS
D	PLAT WASHER $\varnothing \frac{5}{16}$ " 	14PCS
E	BOLT $\varnothing \frac{5}{16}$ " *1 1/2"	2PCS
F	BOLT $\varnothing \frac{5}{16}$ " *2"	12PCS
G	FRONT LEG 	2PCS
H	FRONT CENTER LEG 	1PC
I	SEAT FRAME 	1PC
J	CHAIR BACK 	1PC